

OPERATING MANUAL

PLS HR 1000



**PACIFIC LASER
SYSTEMS**

The Professional Standard

TABLE OF CONTENTS

IntroductionPage 1

Safety InformationPage 2

BatteriesPage 3

KeypadPage 4

FunctionsPage 5

ApplicationsPage 6,7

Checking Calibration.....Page 7

Specifications.....Page 8

Warranty.....Page 9

PLS HVD 505R DetectorPage 10,11

INTRODUCTION

The PLS HR 1000 is a self-leveling laser used for exterior horizontal layout. The rechargeable NIMH battery pack contains micro-controlled charging technology. The HR1000 may also be used with alkaline batteries in an optional separate battery pack.

CAUTION: DO NOT ATTEMPT TO CHARGE STANDARD ALKALINE BATTERIES OR WARRANTY WILL BE VOIDED.

The instrument is water resistant and may be used in light rain, if necessary. Unit may not be submerged in water.



Safety instructions

Laser Safety

The PLS HR 1000 is a class III laser according to 21CFR1040. Follow the instructions on the warning labels which are shown in the following illustrations:



PLS HR 1000
Laser Power:
635 nm
<5mW
Laser Class III

Do not remove the attached warning labels. The manufacturer and its dealers are not liable for any defects and the consequences from this removal.

! Attention ! The internal laser sources comply with laser classes II and III. Do not disassemble the instrument. In case of inappropriate repairs, laser radiation may arise in excess amounts of the marked labels and liability may be incurred if there is damage. In cases of inappropriate processing, malfunctions are possible without external visible damage.

DO NOT ATTEMPT TO CHARGE STANDARD ALKALINE BATTERIES.

Attention: This instrument contains NIMH rechargeable batteries. Batteries must be recycled or disposed of properly. WEEE-Reg.: DE23874031



The PLS HR 1000 uses rechargeable NIMH batteries.

For on-board chargeable battery, insert the battery re-charger receptacle plug in the charging panel outlet of the battery cover back.

Insert converter's AC receptacle plug in an AC outlet and insert the converter's DC receptacle plug in the charging panel's DC outlet.

When the charging lamp is on, charging is in process.

When the charging lamp is green, charging is completed.

NOTE: The charging process takes approximately 7 hours to complete for rechargeable batteries.

AC/DC converter's suitable power range:
50-60Hz;
voltage
85V-265V.

Optional Alkaline Battery Pack



Standard NIMH Re-chargeable Battery Pack

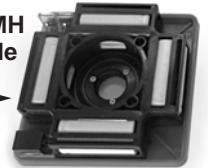

If it is necessary to replace the NIMH battery, the battery chamber may be removed by turning the lock washer on the battery chamber. Purchase replacement battery chamber from an authorized PLS dealer.

Use PLS HR 1000 with caution in humid or wet weather conditions. Do not put the laser back into the case unless it is thoroughly dry. Condensation may corrode the battery connections and/or cause distortion of beams in lighthouse.

KEYPAD OPERATION FUNCTIONS AND INDICATORS

- 1) POWER SWITCH ON/OFF
- 2) POWER LIGHT
- 3) LOW BATTERY INDICATOR
- 4) TILT OR ADS

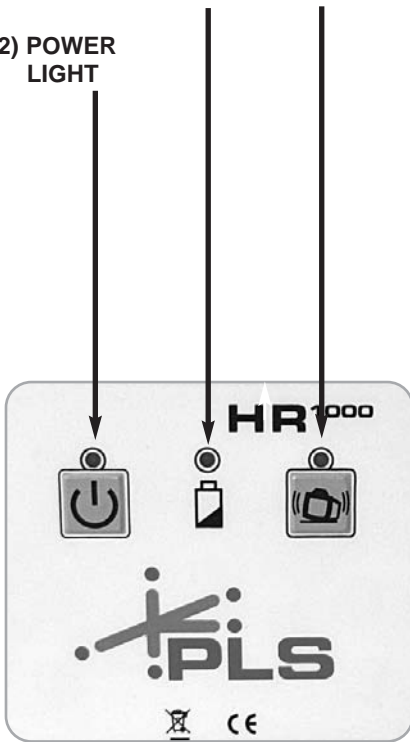

- 1) Power switch: turn on or off unit.
- 2) Power light: red light, power on.
- 3) Low Battery Indicator: LED blinks, the battery should be charged or replaced.
- 4) Tilt or ADS (automatic drift system) blinks slowly when active, blinks quickly to warn user of a change in alignment from original set up.

FUNCTIONS

Power switch



Press 1  (See keypad chart) The unit is self-leveling and power light is lit. Press the key again and the unit will turn off.

Rotation Mode

After laser has automatically leveled, the laser beam stops blinking. The laser will rotate at 1000 r.p.m. If the gradient exceeds $\pm 5^\circ$, the laser will not rotate.

NOTE: If the unit does not level within 5 minutes, it will shut off.

Automatic Drift System

Press 4. Press the TILT key, the power indicator blinks slowly. After the instrument has leveled automatically for about 3 seconds, the ADS function is activated. The power indicator will blink quickly, and automatic leveling function shuts off when the instrument is disturbed by external circumstances. At the same time, the laser module will stop scanning and start blinking.

Height Transfer (Leveling)

Turn the instrument on. The leveling

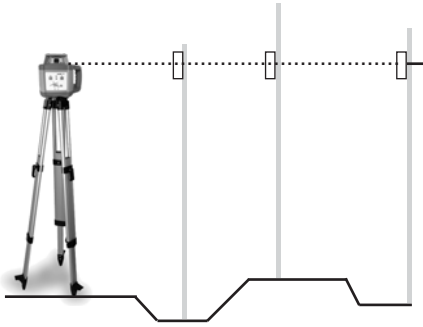

LED is flashing and the instrument is self leveling. If the LED lights continuously the rotary head starts and the laser beam will be turned on. Attach the PLS HVD 505R Detector at this reference point on a rod and move this height to zero. Now the respective difference in levels to the reference height can be measured on the ground. It is useful to use a flexible rod to measure positive and negative values simply.

The PLS HR 1000 should be checked, like all measuring instruments, before use. Set the PLS HR 1000 on a stable surface. Turn the laser on and let it level. Mount the PLS HVD 505R Detector at a fixed distance, e.g. at 90 feet, and move it onto the laser plane. Now turn the instrument around to each 90° point and let the instrument level. In each case, measure the difference to the first height. If the deviation is smaller than 3/32 inch, the instrument is within the specification. In the case of larger deviations the instrument has to be calibrated.

ROTARY SPECIFICATIONS

PLS HR 1000:

Accuracy:	+/- 3/32 inch @100 feet 2.4mm @ 30meters
Leveling range:	± 5°
Operation range:	Radius +/- 1000 feet w/detector 304 meters
Rotation speed:	1000 rpm
Light source:	laser diode, wavelength 635nm, <5mW
Operating Temp:	4° F (-15C) to 122° F (50° C)
Storage Temp:	-22° F(-30° C) to 140° F (60° C)
Laser Class:	III
Power supply:	NIMH Batteries Pack Optional- Alkaline Battery Pack
Operating time:	approximately 20 hours
Charging time:	maximum 7 hours (NIHM ONLY)
Protection grade:	IP65 (Water- resistant), not submersable
Size / Weight:	7.5 inch x 8 inch x 6 inch 190.5mmx200mmx152mm 4.9 lbs (unit only) 2.22 kg
Charger LDG 2+2:	
Input:	100-240V AC/47-63Hz
Output:	12V / 1.25A

Design and specifications are subject to change without prior notice.

WARRANTY

In the event of a claim please contact your PLS dealer or PLS. Attempts at repair or detectable improper treatment will void any warranty claim. Please use the original transport case for shipment.

This product is warranted by PLS • Pacific Laser Systems to the original purchaser to be free from defects in material and workmanship under normal use for a period of two years from the date of purchase. During the warranty period and upon proof of purchase, the product will be repaired or replaced (with the same or similar model at our option) without charge for either parts or labor through PLS. The purchaser shall bear all shipping, packing and insurance costs. Upon completion of the repair or replacement, the unit will be returned to the customer, freight prepaid. The warranty will not apply to this product if it has been abused or altered. Without limiting the foregoing, battery leakage, dents or gouges to the plastic housing, broken optic windows, damage to the switch/LED membrane are presumed to result from misuse or abuse. Tampering with or removal of the caution or certifications labels voids this warranty.

Neither this warranty nor any other warranty, express or implied, including implied warranties of merchantability, shall extend beyond the warranty period. No responsibility is assumed for any incidental or consequential damages. This warranty gives you specific legal rights, and you may have other rights which vary from state to state.

1. SPECIFICATIONS

Available Distance: From rotary PLS HR 1000 (2.0 ft.) Accuracy: Precise detecting: $\pm 1\text{mm}$ ($\pm 0.04\text{in}$)
 Rough detecting: $\pm 2\text{mm}$ ($\pm 0.08\text{in}$)
 Detecting Indication: Bi-surface LCD, buzzer
 Power: DC9V alkaline battery
 Automatic Power-off Time: Approx. 20 minutes
 Working Temperature: -20C° to $+50\text{C}^\circ$ (-4°F to $+122^\circ\text{F}$)
 Dimensions: 135 (L) X 65 (W) X 24.5 (H)mm
 6" x 2-3/4" x 1"
 Weight: 0.15kg (0.44lbs) (with battery)

2. LCD

Precise Detecting
 Reference Position
 Display: 

Rough Detecting
 Reference Position
 Display: 

Higher than
 reference
 (fast
 frequency
 beep)

In reference
 line (long
 beep)

Lower than
 reference
 (slow
 frequency
 beep)

Poor Power:

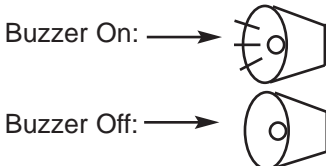
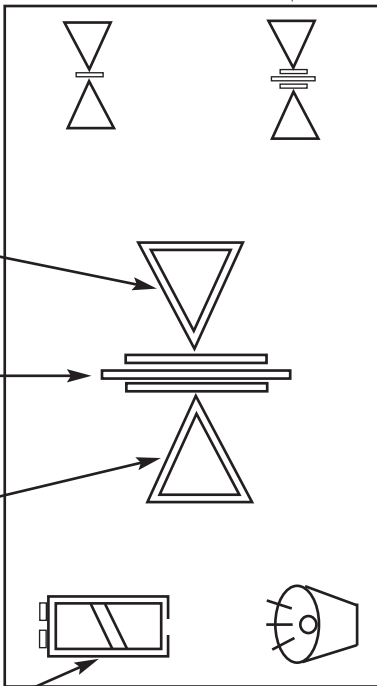

3. PANEL

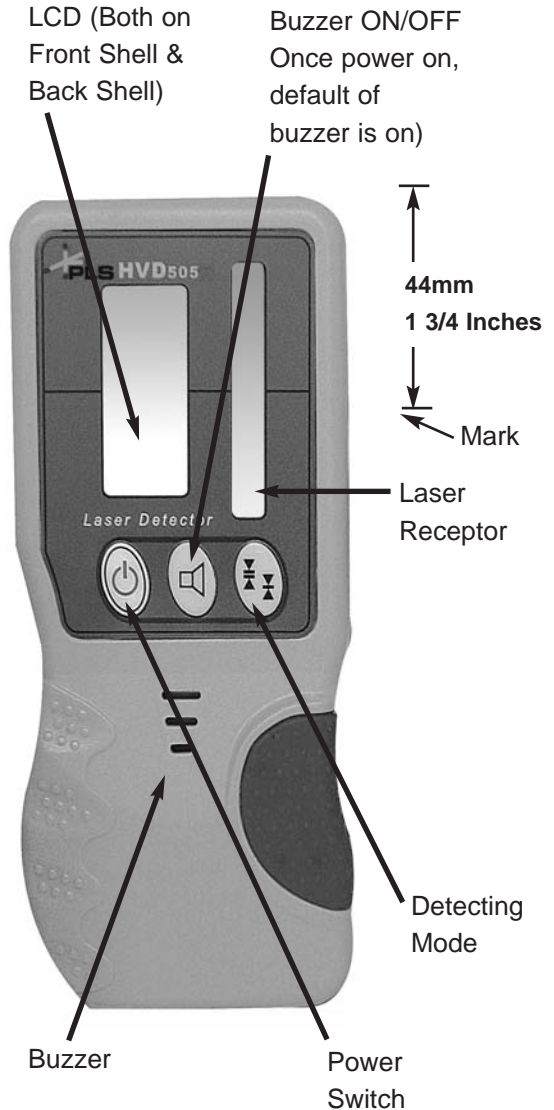



The Professional Standard

**PACIFIC LASER SYSTEMS
2550 KERNER BLVD.
SAN RAFAEL, CA 94901**

WWW.PLSLASER.COM

1 800 601 4500